

# Flanges and their joints

## Circular flanges for pipes, valves, fittings and accessories

### PN designated - Part 1: Steel flanges

This European standard specifies requirements for circular steel flanges in PN designations PN 2,5 to PN 400 and nominal sizes from DN 10 to DN 4000.

This standard specifies the flange types and their facings, dimensions, tolerances, threading, bolt sizes, flange face surface finish, marking, materials, pressure/ temperature ratings and flange masses.

### FLANGE FACING TYPES ACCORDING TO DIN EN 1092-1

Type A: flat face	Type D: groove face	Type G: O Ring recess
Type B: raised face	Type E: spigot	Type H: O Ring groove
Type C: tongue face	Type F: recess	

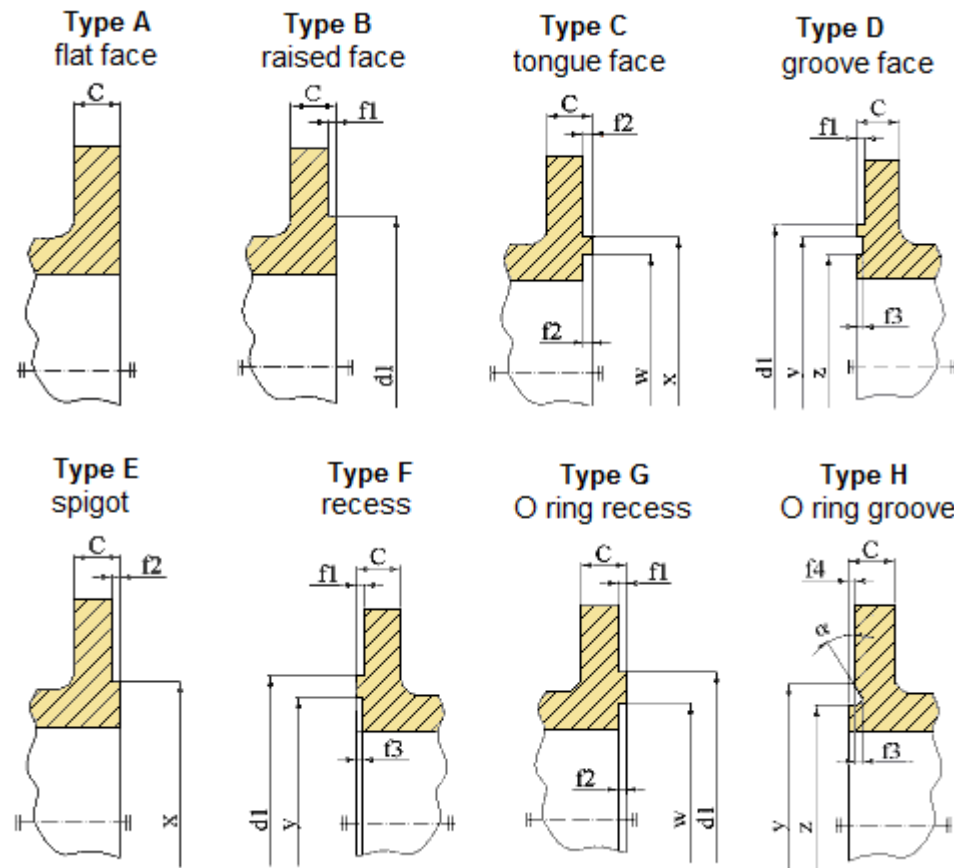

### Flange facing dimensions

units [mm]

DN	PN												f1	f2	f3	f4	w	x	y	z	α	R
	2.5	6	10	16	25	40	63	100	160	250	320	400										
	d1																					
10	35	35	40	40	40	40	40	40	40	40	40	40	2	4.5	4	2	24	34	35	23	-	2.5
15	40	40	45	45	45	45	45	45	45	45	45	45					29	39	40	28	-	
20	50	50	58	58	58	58	58	58	58	58	58	58					36	50	51	35		
25	60	60	68	68	68	68	68	68	68	68	68	68					43	57	58	42		
32	70	70	78	78	78	78	78	78	78	78	78	78					51	65	66	50		
40	80	80	88	88	88	88	88	88	88	88	88	88					61	75	76	60	41°	
50	90	90	102	102	102	102	102	102	102	102	102	102					73	87	88	72		
65	110	110	122	122	122	122	122	122	122	122	122	122					95	109	110	94		
80	128	128	138	138	138	138	138	138	138	138	138	138					106	120	121	105		
100	148	148	158	158	162	162	162	162	162	162	162	162					3	5	4.5	2.5	129	
125	178	178	188	188	188	188	188	188	188	188	188	188	155	175	176	154						
150	202	202	212	212	218	218	218	218	218	218	218	218	183	203	204	182						
200	258	258	268	268	278	285	285	285	285	285	285	285	239	259	260	238						
250	312	312	320	320	335	345	345	345	345	345	345	-	292	312	313	291						
300	365	365	370	378	395	410	410	410	410	-	-	-	343	363	364	342						
350	415	415	430	438	450	465	465	465	-	-	-	-	395	421	422	394						
400	465	465	482	490	505	535	535	535	-	-	-	-	447	473	474	446						
450	520	520	532	550	555	560	560	560	-	-	-	-	497	523	524	496						
500	570	570	585	610	615	615	615	615	-	-	-	-	349	375	376	548					27°	3.5
600	670	670	685	725	720	735	735	-	-	-	-	-	649	675	676	648						
700	775	775	800	795	820	840	840	-	-	-	-	-	751	777	778	750						
800	880	880	905	900	930	960	960	-	-	-	-	-	856	882	883	855						
900	980	980	1005	1000	1030	1070	1070	-	-	-	-	-	961	987	988	960						
1000	1080	1080	1110	1115	1140	1180	1180	-	-	-	-	-	1062	1092	1094	1060	28°	4				

Flange facing types C, D, E, F, G and H are not used for PN 2,5 and PN 6.  
Flange facing types G and H are only used for PN 10 to PN 40.











